

Grays Harbor Raceway

2026 360 Sprint Car Rule Book



1-31-2026

PLEASE NOTE THAT ANY UPDATES TO THESE RULES WILL BE POSTED ON:

www.graysharborraceway.com

Circle Motion Promotions, LLC

Grays Harbor Raceway

P O Box 1984, Snohomish WA 98291

Office: 360-482-4374

www.graysharborraceway.com

graysharborraceway@hotmail.com

RULE BOOK DISCLAIMER

- The rules and/or regulations set forth herein are designed to provide the orderly conduct of racing events and to establish minimum acceptance requirements for such auto racing events. These rules shall govern the condition of all events, and by participating in these events, all participants are deemed to have complied with these rules.
- **NO EXPRESS OR IMPLIED WARRANTY OR SAFETY SHALL RESULT FROM PUBLICATION OF, OR COMPLIANCE WITH THESE RULES AND/OR REGULATIONS.** These rules and regulations are intended as a guide for the conduct of auto racing at Grays Harbor Raceway (GHR) Events and are no way a guarantee against injury, or death to a participant, spectator, officials or others.
- The Race Director and/or Technical Director shall be empowered to permit minor deviation from any of the specifications or rules herein, or impose any further restrictions that, in their opinion, do not alter the minimum acceptable requirements.
- Any interpretation of, or deviation from these specifications or rules is left to the discretion of the Race Director, Race Manager and/or Technical Officials. Their decision is final. Minor drivers and their parents are responsible to read and understand the rules and regulations set forth in this rule book.
- **COMPETITOR OBLIGATION:** Any driver entering any racing event is considered to have inspected the track and determined that all conditions are satisfactory. If the driver does not feel that conditions are satisfactory, then the driver should not race. The driver further acknowledges that he is aware that auto racing involves risks and that by competing in that event the driver assumes these risks with full awareness and knowledge.
- **ALL RULES ARE SUBJECT TO THE INTERPRETATION OF THE TRACK MANAGEMENT AND OFFICIALS, ANY EQUIPMENT THAT IS CONSIDERED EXOTIC OR NOT IN THE SPIRIT AND INTENT OF THE RULES WILL BE CONSIDERED ILLEGAL FOR COMPETITION. IN THE INTEREST OF FAIRNESS THE RULES MAY BE ADJUSTED TO CREATE A BALANCE IN COMPETITION.**
- The spirit and intent of the rules is the standard by which all GHR track events will be governed. GHR Track Tech officials are authorized to decide if an equipment change, or modification is an attempt to circumvent these rules. GHR Track officials can and will disqualify a race car in violation of the spirit or intent of these rules. If this rule book does not specifically state that you can alter, change or otherwise modify something on your car, you should consider it a violation of these rules. No part is deemed to have been approved by GHR track officials by passing through prior technical inspections. **SPIRIT OF THE RULE:** Spirit of the rule means very simply, the intent of every rule and classifications. Additional adjustments, alterations, modifications, and/or replacements not covered by written rules should NOT be assumed to be legal under the SPIRIT OF THE RULE.

Index

1.0 Safety Rules

- A. Cap Insurance
- B. Personal Safety Gear
- C. Seat
- D. Seat Belts
- E. Driver Area
- F. Fire Control
- G. Chassis Safety

2.0 Chassis Rules

- H. Chassis
- I. Support Bars
- J. Body
- K. Nerfs
- L. Brakes
- M. Wheels
- N. Tires
- O. Rear Axle
- P. Shock
- Q. Bleeders

3.0 Wings

- A. Wings
- B. Top Wing
- C. Front Wing

4.0 Weight

- A. Weight

5.0 360 Engine Rules

- A. Engine Rule
- B. Injector
- C. Heads
- D. Fuel
- E. Fuel System
- F. Mufflers

6.0 Race Format

- A. Registering
- B. Line-Ups
- C. Qualifying
- D. Heat Races
- E. Main Events
- F. Starts
- G. Re-starts
- H. Tech
- I. Raceceivers

J. Transponders

K. Work area

7.0 Points

A. Points

No Driver, car owner, mechanic or pit crews shall have claim for damages, expenses or otherwise against Grays Harbor Raceway, promoter, or any officials, by reason of disqualification, confiscation, or damage to, either race car or driver or both; and car owners, driver, mechanics and pit crews agree the track is in safe condition if they take part in racing activities.

1.0 Safety Rules

It is the car owners' responsibility to ensure his/her car is safe and properly maintained for racing.

A. Cap Insurance

- a. Cap Insurance for all minor drivers (14 to 17 years old) mandatory for 2026 race season and Cap Insurance will be mandatory for all drivers in 2027 race season. <https://www.competitiveadvantageprogram.com/>

B. Personal Safety Gear

- a. Racing shoes and gloves mandatory.
- b. Fire retardant neck collar or Hans type neck collar recommended.
- c. The following must be worn during any event including wheel packing. All applicable items must be Nomex and SFI rated.
- d. SFI Fire suit, minimum two layers. Fire retardant Underwear, Head & Foot Socks.
- e. Full face Snell SA 2015 helmet or newer.
- f. Arm restraints
- g. Right side head net, or approved head restraint seat.
- h. The first offense seen without the safe gear on while driving you will be disqualified for that event and removed from the racing surface.
- i. The second offense will be disqualified for the remainder of the night and loses points for that night.

C. Seat

- a. High-back aluminum double wrap around racing seat.
- b. Installed to manufactured specification.
- c. Seat must be mounted with a minimum of 3/8-inch grade 5 bolts. Minimum two bolts in the bottom and two in the back of the seat. Use manufactures recommendations.

D. Seat Belt

- a. **Current five point seat belt harness.**
- b. **Each car will be equipped with a minimum of an SFI 15.5 or SFI 15.1 approved restraint system.**
- c. **UNTIL THE DATE OF THE BELT EXPIRATION (TWO YEARS FROM THE DATE OF MANUFACTURE)**
- d. **LATCH TYPE 5-POINT SEAT BELTS mounted per manufacture. (Must have label) Seat belt restraint systems shall be installed and used in**

accordance with manufacturer's instructions. In any type of manufacturer's installation, the fasteners must be magnetic steel unless using a type of mount in which seat belts wrap around the roll cage.

- e. Seat belt material should not be permitted to come in contact with any sharp or metal edge, including when the material passes through the seat.**

E. Driver Area

- a. Approved roll bar padding on roll bars within range of the driver's head.
- b. Highly recommended padded knee guards.
- c. Driveline hoop. Minimum 1" O.D. x .065 4130 chrome alloy material
- d. Rock Screens are highly recommended.
- e. Sealed firewall between the driver and engine.
- f. Hood must cover the radiator cap and engine.
- g. The floor pan must be securely fastened and extend to each frame rail and from the motor plate to the seat.
- h. Not allowed under the engine or fuel tank.
- i. Only steel or aluminum floor plans will be allowed. Carbon fiber will not be allowed. The floor pan must have a minimum of one hole of ½" diameter or larger for drainage.**
- j. The throttle pedal must have a toe strap.
 - i. Not recommended to mount to the floor pan.
- k. On/off or push/pull ignition switches only. No keys.
- l. No mirrors or communication devices except Raceceiver. Only track officials may talk to drivers, violators will be disqualified & fined \$250.**
- m. Foot operated hydraulic brakes that work required.
- n. The roll cage must be 2" above the driver's helmet.
- o. The driveline must be enclosed in the driver's compartment.
- p. No cockpit adjustable parts except the wing slider.
- q. No electrical disconnects in the cockpit.

F. Fire Control

- a. It is recommended that teams have in the rear of their transporter an easily accessible fire extinguisher of at least 2.5 gal FFF or equivalent.
- b. Fire suppression systems Mandatory. If a fire suppression system is installed, it must be installed and used in accordance with the manufactures instructions, installed securely and meet or exceed SFI 17.3 Specifications**

G. Chassis Safety

- a. Drag Link and LF radius rod must be made of 4130 steel with steel rod ends.

- i. Drag Link must be tethered to the frame.
- b. TORSION ARM STOPS MANDATORY on both sides of the front torsion bars. The retainer may be of the rod-type with a securing cap or inserted with an expanding mandrel, any other Torsion arm stop design must be approved by track Tech.
 - i. Torsion arm stops must be installed and used in accordance with the manufacturer's instructions.
- c. Axle tethers and Kingpin tethers are mandatory.
 - i. Tether systems must be installed and used in accordance with the manufacturer's instructions.

2.0 Chassis Rules

A. Chassis

- a. Space frame design only. Roll bars must be 4130 chrome alloy. Minimum size of roll cage will be 1 1/4" x .120 WALL OR 1 3/8" x .095. Cage bracing must be minimum 1" x .065. Must be of modern and normal design.
- b. Slip joints will no longer be allowed in any form.**
 - i. Bolted or clamped slip joints will no longer be allowed.
 - ii. If a current chassis has a slip joint, it will have to be welded to the full circumference of the tube to become solid.
- c. Wheelbase minimum of 82".
- d. Tread width minimum of 48" center to center.

B. Support Bars

- a. Forward all chassis will be required to have additional bars installed to support and decrease the span between the front and rear uprights. The new support bars must be an addition to the front and rear uprights. The left and right-side support bar do not have to be the same. These additional bars will be minimum 1.375 X .083 ASTM4130 normalized steel or equivalent material. Left and right-side support bars may be one of two forms: a "Curved Support Bar" similar to current "safety bar" used in some chassis' or a "Non-Curved Support Bar" similar to the WoO Sprint Car Series Rules.
 - i. The Curved Support Bar will attach to the top rail to create a span between 15" and 20" from the front upright to the support bar. This measurement will be made from the rear point of the front upright to the forward point of the support bar. It will attach to the hip rail and have a gusset attached above the curve to the rear upright at the point opposite of the rear brace/shock mount bar. The outermost point of the curve will be between 4" and 7" measured from the outer edge of the uprights.
 - ii. The Non-Curved Support Bar will be attached to the top rail to create a span between 15" and 20" from the front upright. This measurement will be made from the rear point of the front upright to the forward point of the support bar. The bottom of the

Support Bar will attach to the rear upright at the point opposite of the rear brace/shock mount bar. See drawings below.

- iii. In 2026 the use of extended front upright support bars added to the chassis is recommended. This will likely be mandatory in 2027.

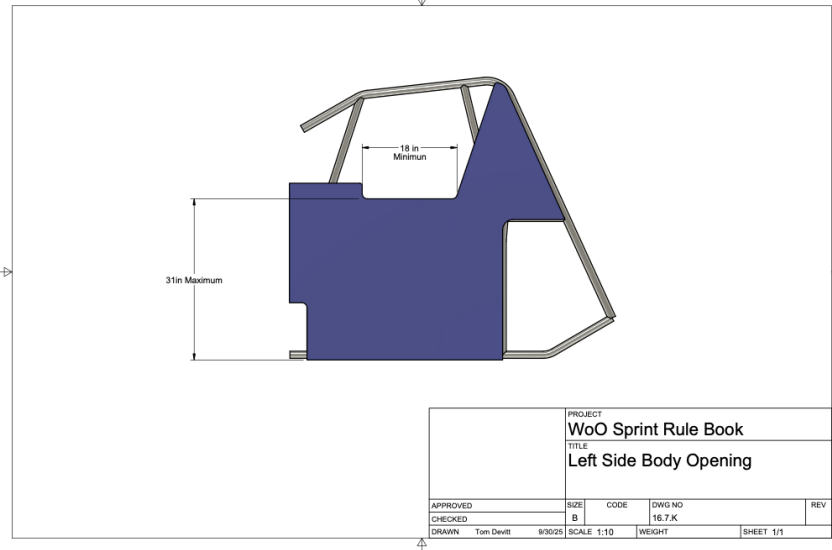
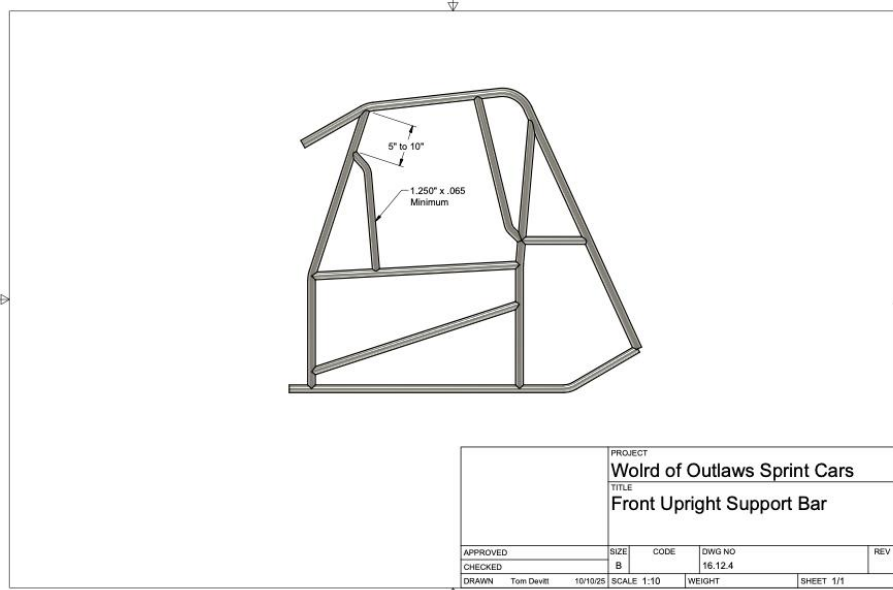

#3 Support Bar Curved Option

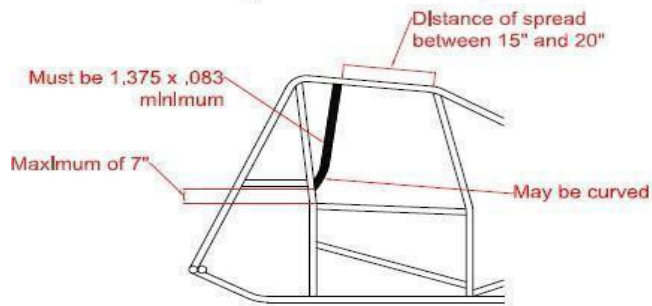

#3 Support Bar

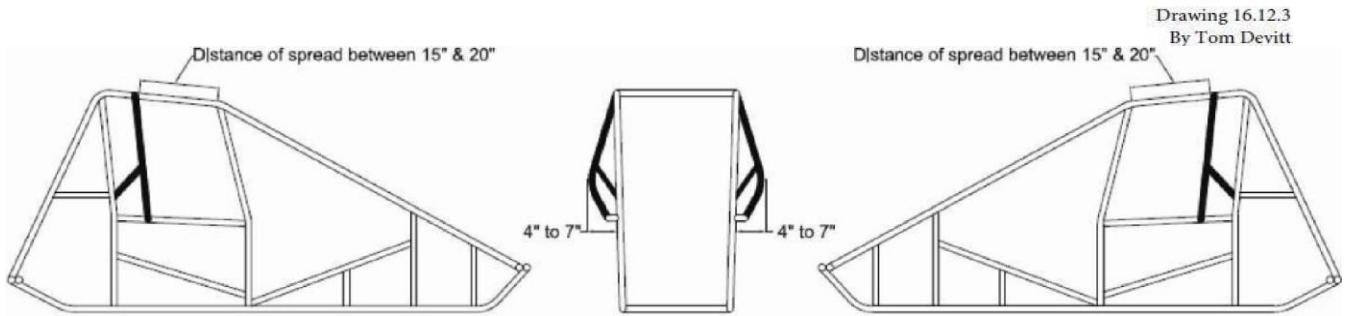
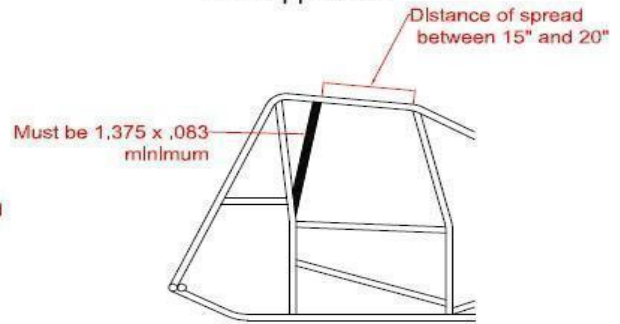

Drawing 16.12.3
By Tom Devitt

Distance of spread between 15" & 20"

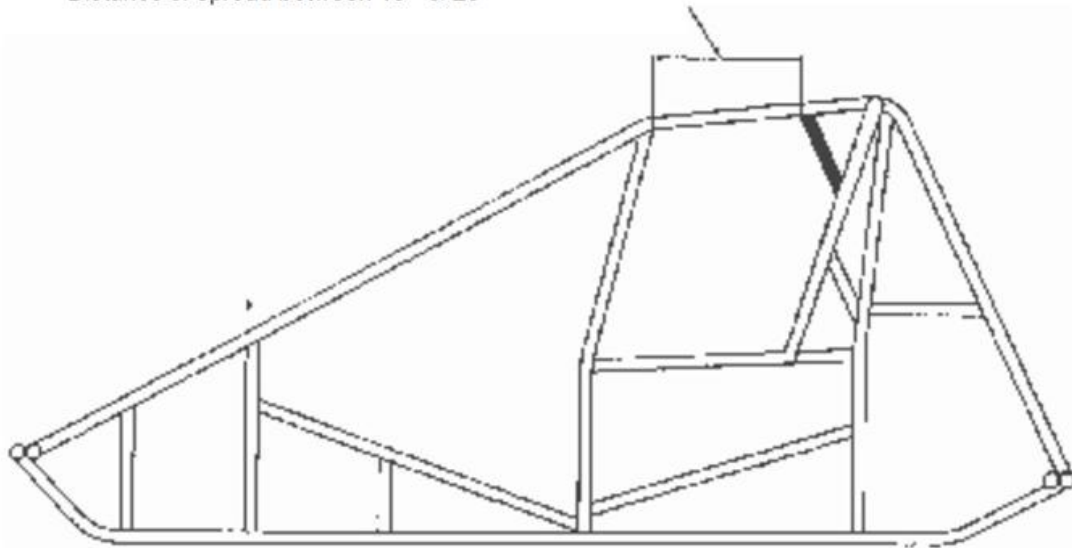

C. Body

- a. The use of an optional left side arm guard, as part of the body, is acceptable as long as it or any other part of the paneling does not prevent left side driver entry or exit. The extension of the body panel above the hip rail may not exceed the measurement per drawing 16.7.K. A maximum of 31" above the lower rail and a minimum of 18" opening front to back. This extension may not be used when the outward curved support bar is part of the chassis.
- b. Body style and design must look like a standard and normal sprint car.

- i. No unusual shaped or added panels to deflect or catch air.
- D. Nerfs
 - a. Front, rear, and side nerfs required at the start of the race.
 - i. All nerfs and bumpers must be attached with a minimum 3/16" steel fastener.
 - ii. No pop rivets.
 - b. Side nerfs can not extend past tires.
 - i. Nerfs must be attached to the chassis at 3 points.
 - ii. Front nerf minimum 12" wide and rear nerf minimum 6" vertical contact area.
 - iii. All nerfs and bumpers must be steel.
 - iv. Minimum 1" O.D.
 - v. No air deflectors on nerfs or bumpers.
- E. Brakes
 - a. Foot operated hydraulic brakes that work required.
 - b. Brake rotor material optional.
- F. Wheels
 - a. The maximum with for the right rear wheel will be 18".
 - b. The maximum with for the left rear wheel will be 15".
 - c. All wheels must be approved for racing.
 - d. All wheels must be approved for racing. Wheel covers must be attached by minimum 5 Dzus fasteners or 3 5/16 flangehead bolts. Approved fastening systems: Keyser Manufacturing, part #100 7-101. Wehrs Manufacturing Part # (WM377A-312 Aluminum 5/16) (WM3775-312 Steel 5/16) Triple X Chassis Part # SC-WH-7810 (for 1" spring) / SC-WH-7820(for 1 3/8" spring) Smith Precision Products Part # MC-516-18.
 - e. Wheel wing nuts can not extend past the rim.
 - f. No clip-on wheel weights.
- G. Tires
 - a. All tires must be "Hoosier".
 - i. 2.12.1 RR H15 105/16-15 or 105/18-15 HTW or 105/16.0-15 Medium compound.
 - ii. 2.12.2 LR 15.0/90, 92, 94, 96-15 H12 or H15 Compound, D10 and RD12 compound also allowed.
 - iii. 2.12.3 Front 85/8.0-15 D10, D12.
 - b. No chemical softening.
- H. Rear Axle
 - a. The maximum inside diameter of the rear axle will be 1.8750".
 - b. Ultra-light rear axles are not recommended for 2026 and will not be allowed in 2027.
- I. Shocks
 - a. One shock per wheel.
 - b. Shock absorbers may not be cockpit adjustable.
- J. Bleeders
 - a. Digital bleeders are allowed but cannot be remotely controlled.
 - b. Diaphragm bleeders are approved.

- c. Air may not be introduced to the tire from any onboard system.

3.0 Wings

A. Wings

- a. No dual stage wings.
- b. No offset or angled shape to the body or side panel design.
- c. Wing T-post should be built from 1" x .083" minimum ASTM4130 normalized steel or equivalent material.
- d. Parts made from castings must be HRP Heat treated type.
- e. Side panels mounted at 90 degrees to the main body.

B. Top Wing

- a. Top wing surface area not to exceed 25 square feet.
- b. Top wing side panels maximum vertical height is 30".
- c. Curved top wings may not exceed 2 1/2" of total dip in the top surface measured from front to back. No wicker bills allowed.
- d. Top wing may be of 'Flat Top' design. Main body thickness not to exceed 9". **Maximum 2"** wicker bill allowed.

C. Front Wing

- a. Nose wing top surface shall be maximum 6 square feet.
- b. 1" Wicker bill allowed on nose wings.

4.0 Weight Rule

A. Weight Rule

- a. All classes are minimum weights at the conclusion of an event and include the driver.
- b. No allowance for parts lost during the event.
- c. Cars found underweight will be disqualified and forfeit money and points for said event.
- d. All cars weighing will have a crew to push cars on & off scales.
- e. **Top three to tech** must weigh before returning to the pit stall.
 - i. Cars that do not stop and weigh may be disqualified. If in doubt, STOP at the scales. The only exception is if no weigh-ins are announced by the Management or Race Director.
- f. Added weight must be between frame rails and axles, securely fastened. No single weight over 20 lbs, painted white and has the car number on it. Must meet tech approval. If weight falls off the car at any time on the racing surface will be disqualified.
- g. 360 class 1,475 lbs.
- h. Wingless events 1,425 lbs.

5.0 360 Engine rules

A. Engine

- a. Normally aspirated, piston driven engines only.
- b. Maximum cubic inch 360.
- c. No titanium cranks or rods.
- d. Blocks can be steel or aluminum.

- e. If an aluminum block is used a total of 50 pounds of lead must be safely secured in front of the rear motor plate and behind the front axle.
 - f. Absolutely no lightening of aluminum blocks.
 - g. Oil pan must have a 1" inspection plug on the side.
 - h. Coil, power boxes and all electrical components must be on the engine side of the firewall.
 - i. No electrical disconnects in the cockpit.
 - j. No traction control devices.
 - i. Violators will be **fined** and **suspended**.
 - k. No external coolers.
- B. Injectors
- a. Injectors must be individual stack per cylinder design with a single round butterfly.
 - b. Injectors: 2 3/16 inch maximum inside diameter of injector stack -2.187 at least 3 inches in length. Note: Larger injectors may be used, but sleeves a minimum of 3 inches in length must be installed in stacks above the Butterflies. No relief hole may be drilled above the Butterfly on any injector. No Alteration of injector manifold mounting holes will be allowed.
 - c. Injector nozzles not permitted in the cylinder head
- C. Heads
- a. Aluminum heads are permitted.
 - i. Cylinder heads can be legal ASCS heads.
 - ii. Must be 23 degrees (+/- 2 degrees).
 - iii. We will be evaluating the non-ASCS head rule at the end of the **2026** year and deciding whether to continue to allow non-ASCS heads. May also be re-evaluated during the **2026** season.
- D. Fuels
- a. Methanol fuels only.
 - i. No performance enhancing additives.
 - ii. Including but not limited to Nitromethane and propylene oxide.
- E. Fuel System
- a. The main fuel line must have a ¼ turn shut off in reach of the driver.
 - b. Fuel lines must be reinforced pressure hose.
 - i. No plastic lines.
 - c. Approved fuel tanks with bladders only.
 - i. Flush mount caps and non-spill vents.
 - ii. Fuel tanks shall retain the traditional sprint car tank shape; no square back shapes.
 - iii. **Highly recommended to have the fuel cells mounted with at least 6 mounting points.**
- F. Mufflers
- a. Unaltered, functional mufflers intact at all times.
 - b. Large oval Flow Master (#5354510).
 - c. Large Spin Tech box mufflers (#1555).
 - d. Schoenfeld (#14272735).

- e. Max dba 95 @ 100'.
- f. **MAX 23 DEGREE TURN DOWNS.**

6.0 Race format

A. Registering

- a. All owners will register their car number. First come first served. Last year's numbers will be held through playday, unless released by the previous owner.

A. Qualifying

- a. Sprint cars will draw a pill for qualifying order. All cars to tech (scales) after their qualifying lap upon leaving the track and before going to their pit.
 - i. If a car is unavailable and misses its qualifying spot by more than two cars, said car will take one lap at the end.
 - ii. The best the car can start is behind the inversion of the heat race.
- b. Cars that are too loud are disqualified and may change mufflers and take one lap at the end. The best the car can start is behind the inversion of the heat race.
 - i. Cars that don't meet the dba requirement will not race.
- c. Cars that take one lap at the end may not start the 'A' main any further up than the back of the inversion or fifth, whichever is greater.
- d. If an event is delayed and qualifying is cancelled, heat races will be lined up according to car owner points. #1 on the pole of heat one, #2 on the pole of heat two, #3 on the pole of heat three, etc.
- e. If a car in any class has not drawn a pill before 4:00pm, it will retain the next highest number available for said class.

B. Heat Races

- a. Sprint cars will line up straight up by their qualifying time with the top 4 inverted.
- b. 27 Cars and Under
 - i. Classes will have two or three heats. The top five cars will retain their time and transfer to the 'A' main, provided they attempt to take the checkered flag.
- c. 28 Cars or More
 - i. Classes will have up to four heats. The top four cars will retain their time and transfer to the 'A' main, provided they attempt to take the checkered flag.
- d. Sprint heat race transfer cars will line up straight up by their original qualifying time with the inversion for the 'A' main start, provided they take the checkered flag in their heat.
- e. Drivers must take the checkered flag in their heat to get their time back. If you do not take the checkered flag, you will start behind the transfer cars. In the event of a 'B' main, you will be lined up in the 'B' main by your time.
- f. Classes with 19 or more cars will have a 'B' Main.

C. B Main Event

- a. The B Main will line up straight up by original qualifying time or pill draw. Transfer cars to the A Main will start at the rear of the A Main according to the B Main finish.
- b. If a B Main is cancelled, cars that did not transfer directly into the A Main from their heat race will be lined up from the start of the B Main.
- c. A Main cars that scratch after their heat race will be replaced by additional B Main transfers.

D. A Main Event

- a. A Main invert will be drawn by the winner of the first heat race to determine the A Main inversion of 0, 4, 6, 8, or full invert.
- b. A Main will be up to 18 cars. It is the Promoter's option to add cars.
- c. New or inexperienced drivers will start at the rear of all races for at least two weeks or until officials notify the driver he can start in a qualified spot.
- d. Cars that enter the work area will be given two full laps when the line up is set by the race director.
- e. Only cars that were involved in the yellow or red flag will be given the two laps.
- f. When said car uses up the two laps will not be given another set of laps.
- g. With 5 laps or less remaining in the race, there is no work area time. When the lineup is correct the race will resume.
- h. Lapped cars will be put in running order behind the lead lap cars when 5 laps or less remain.

E. Starts

- a. The start will be official with the green flag.
- b. No passing the pace vehicle without permission. Violators will be sent to the pit area.
- c. A white line will be placed on the turn 4 area for all double file starts.
- d. All cars must remain in proper order until they pass the chalk line. If the front row car or cars are out of position a yellow may be displayed, and a warning is given to the offender.
- e. Any other car not in proper position, in the Officials' judgment, may be penalized a minimum of 2 positions for each position gained. This penalty will be imposed on the next race stoppage. If there is no race stoppage the penalty will be enforced at the end of race.
- f. The pole position will set the pace.
- g. The front row will give 2 tries to start the race. If the front row is not able to start the race the 2nd row moves up and the first row back. One try will be given. If this is unsuccessful, Race Director has the choose to go single file start.

F. Restarts

- a. The restarts are single file
- b. The leader will set pace and will start in the box in turn 4
- c. There will be two cones to mark out the restarting box.
- d. Must stay in line, not pass before the cone, hit the cone, or go below the

cone. Any other car not in proper position, in the Officials' judgment, may be penalized a minimum of 2 positions for each position gained. This penalty will be imposed on the next race stoppage. If there is no race stoppage the penalty will be enforced at the end of race.

G. Tech

- a. All cars to tech after their qualifying group.
- b. Top 3 car after the heat race
- c. Top 3 from their main event.

H. Raceceivers

- a. All drivers must use Raceceivers.

I. Transponders

- a. All vehicles must use a working AMB transponder, transponder must have an unrestricted view of the track directly below it, without any metal within a large circumference obstructing it.
- b. Cars that are not picked up on the GHR scoring system will not be scored.

J. Work Area

- a. Cars that enter the work area will be given two full laps when the lineup is set by the race director.
- b. Only cars that were involved in the yellow or red flag will be given the two laps.
- c. When said car uses up the two laps will not be given another set of laps.
- d. With 5 laps or less remaining in the race, there is no work area time. When the lineup is correct the race will resume.
- e. Lapped cars will be put in running order behind the lead lap cars when 5 laps or less remain.

7.0 Points

A. Points

- a. Equal points will be awarded to the driver and the car owner for each event.
- b. Switching car number and driver is not permitted.
- c. All cars not transferring from the B Main will receive 1 point.
- d. If the A Main is a full invert, there will be one (1) point for each position gain from the original official starting position.

Qualifying	Heat Race	Main Event		Optional
1 = 8	1 = 10	1 = 40	10 = 22	19 = 4
2 = 7	2 = 9	2 = 38	11 = 20	20 = 2
3 = 6	3 = 8	3 = 36	12 = 18	21 = 1
4 = 5	4 = 7	4 = 34	13 = 16	
5 = 4	5 = 6	5 = 32	14 = 14	
6 = 3	6 = 5	6 = 30	15 = 12	
5 = 2	7 = 4	7 = 28	16 = 10	
4+ = 1	8 = 3	8 = 26	17 = 8	
	9 = 2	9 = 24	18 = 6	

10 = 1